



On Quantizing General Relativity: *An Overview*

Terry Bollinger
Apabistia Research
April 21, 2022

[CC BY 4.0](#)

The Dual Universe Interpretation of Conformal Cyclic Cosmology

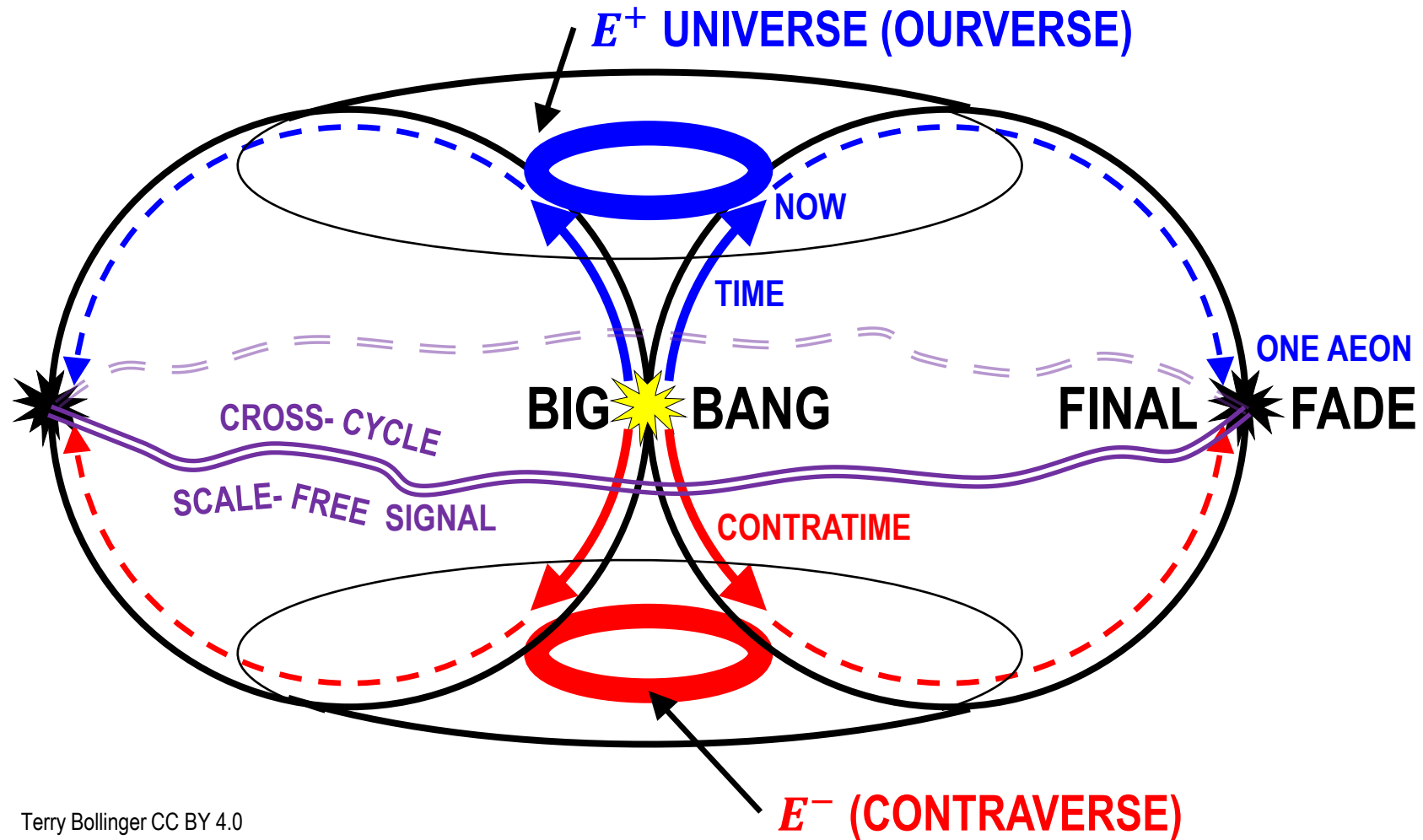

Terry Bollinger CC BY 4.0



Universe and Contraverse

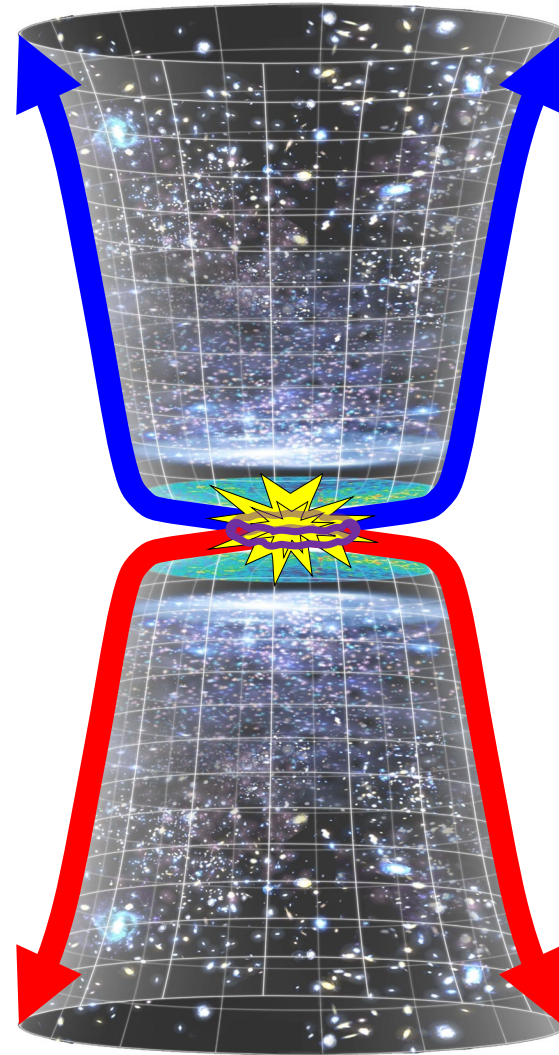



Normalizing Expansion to Angular Time

Scale-Expansion Coordinates

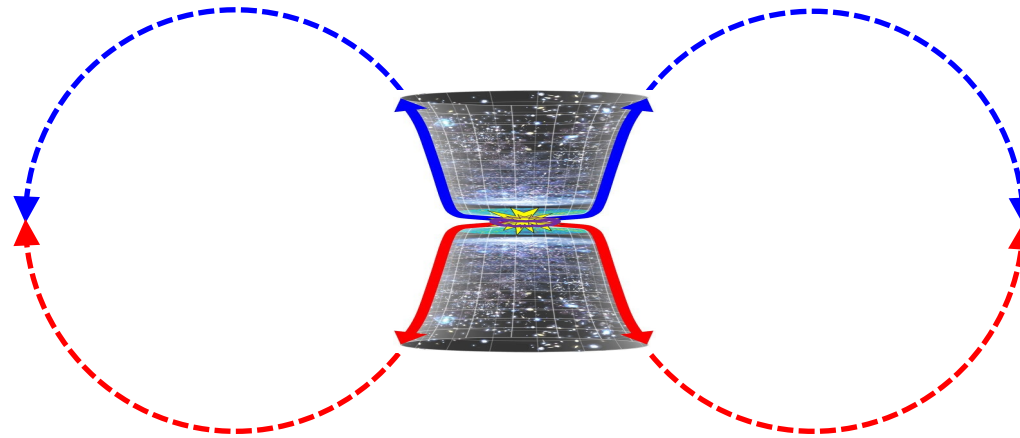

Normalized Angular-Time Coordinates

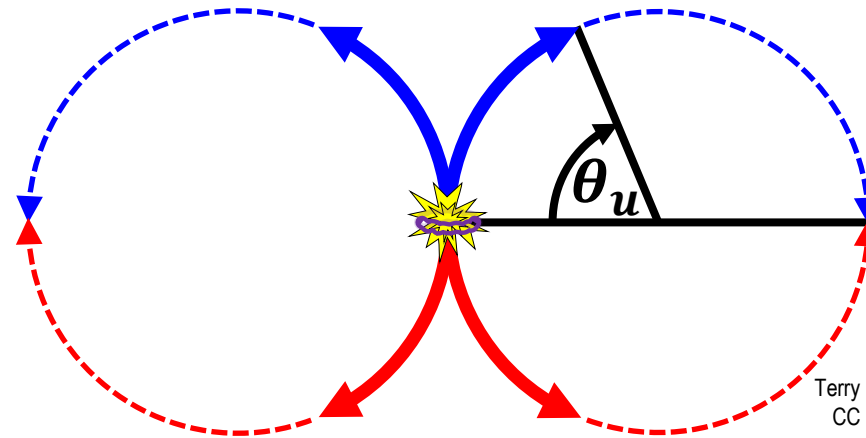

Terry Bollinger
CC BY 4.0

Metrics for One Cycle

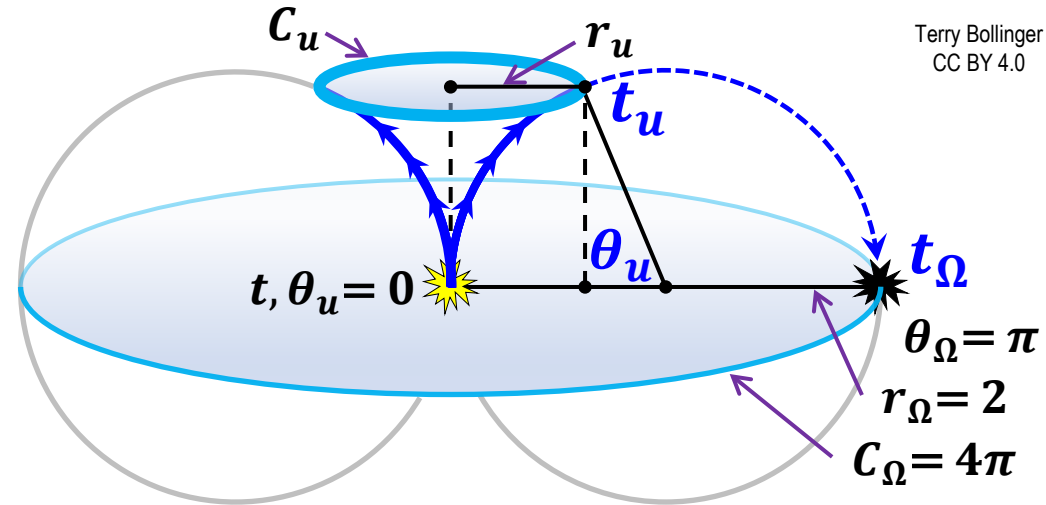

$$t_u = \frac{t}{t_\Omega} \quad \theta_u = \pi t_u = \frac{\pi t}{t_\Omega}$$

$$\begin{aligned} C_u &= 2\pi r_u = 2\pi(1 - \cos \theta_u) = 2\pi \left(1 - \cos \frac{\pi t}{t_\Omega}\right) \\ &= 2\pi(1 - \cos \pi t_u) \end{aligned}$$

$$H_t = \frac{dC_u}{dt_u} = \frac{d(2\pi(1 - \cos \pi t_u))}{dt_u} = 2\pi^2 \sin \frac{\pi t}{t_\Omega}$$

One Full Cycle of a Dual CCC Universe

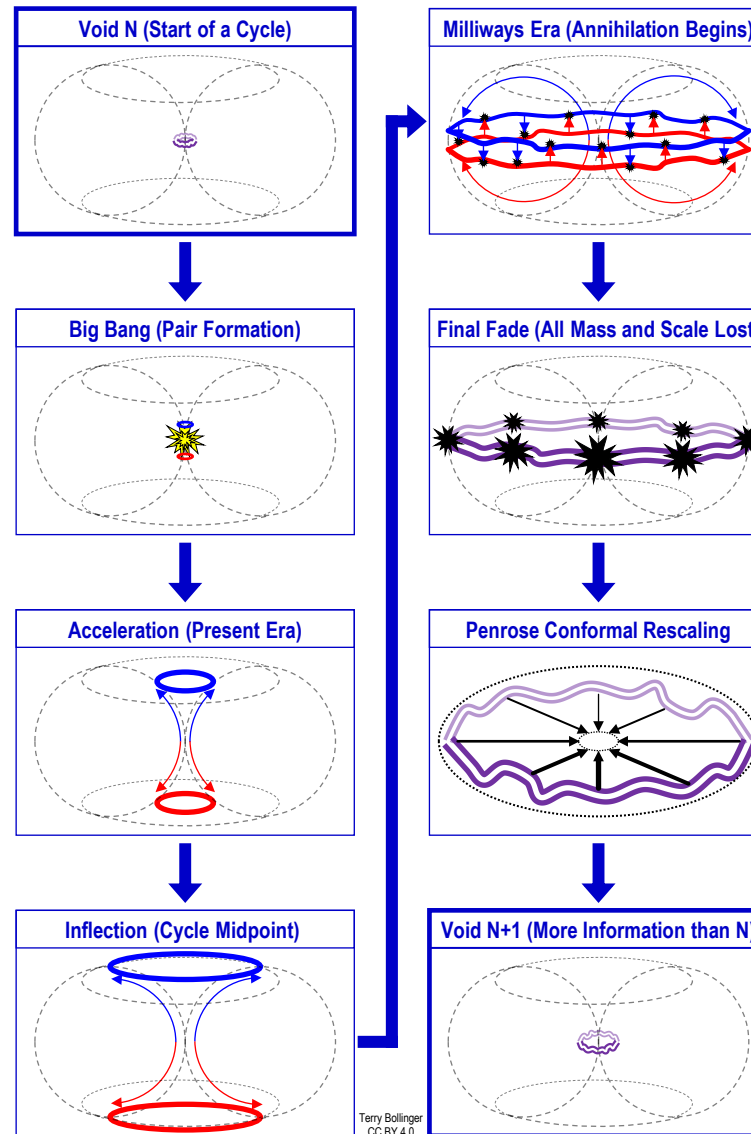

Terry Bollinger
CC BY 4.0



Expansion of Cycle Size, Duration, and Complexity

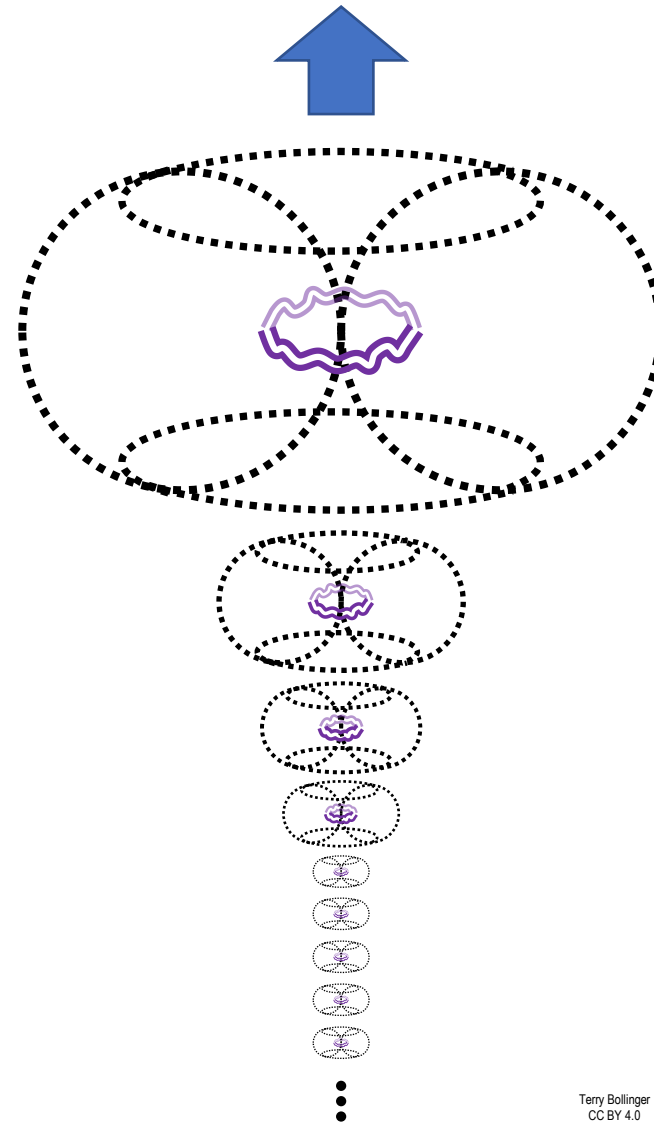

⋮

Terry Bollinger
CC BY 4.0

Time as a Dipole Field

Time as a Dipole Field

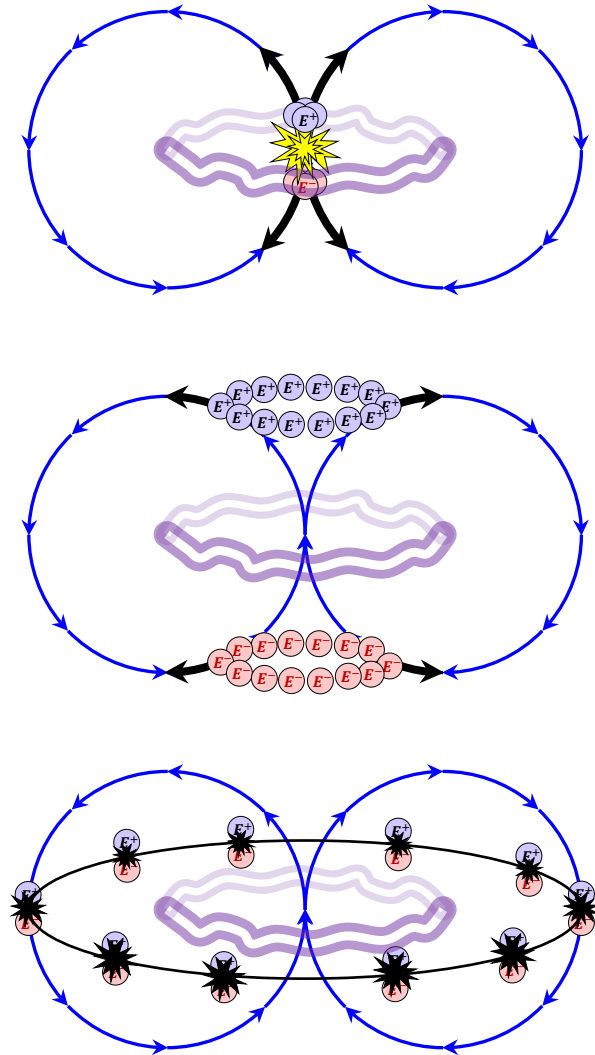

An Electric Model of Dual CCC

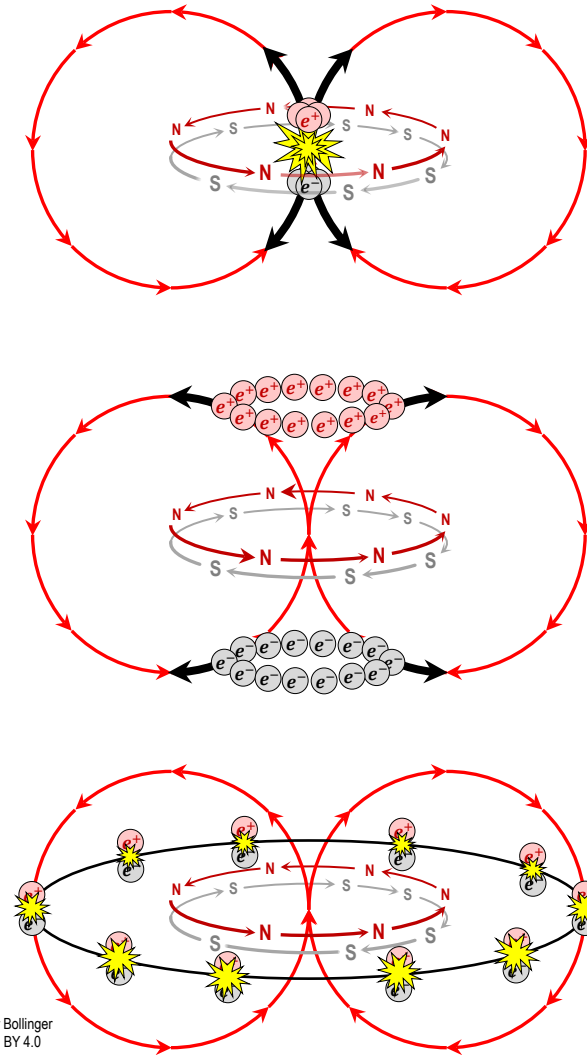

Terry Bollinger
CC BY 4.0



The Ereboic Field in the 7+1 Upverse

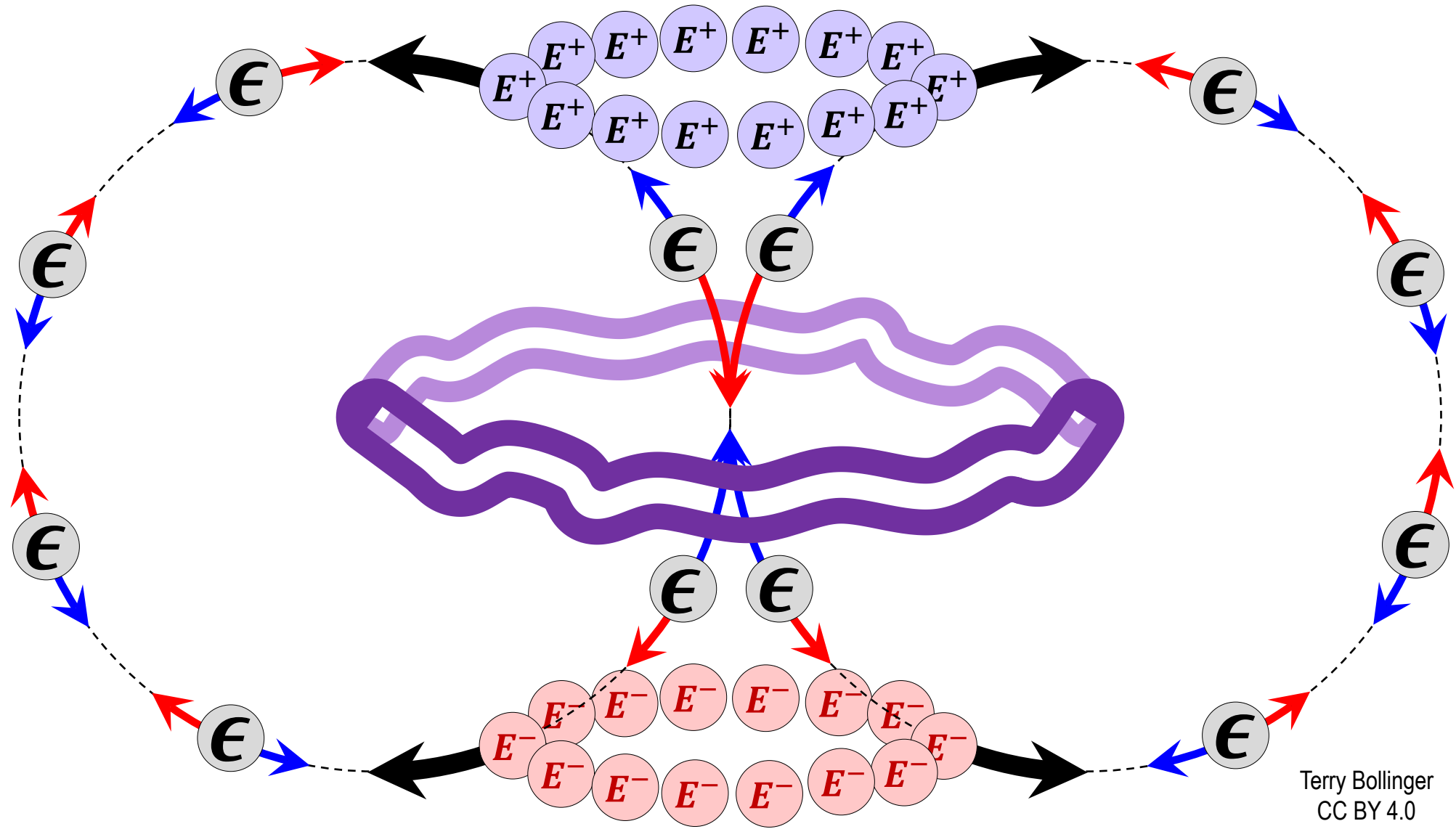

Terry Bollinger
CC BY 4.0

Tohu Charge Displacement Coordinates

Harari-Shupe-Seiberg Chromoelectric (Tohu) Charge Displacement Coordinates

Terry Bollinger CC BY 4.0

$$\begin{aligned} TTT &= T_1 + T_2 + T_3 \\ \overline{TTT} &= -T_1 - T_2 - T_3 \end{aligned}$$

$$T_1 = \bar{r} + \frac{1}{3}e = \text{charge}(\bar{d}_r)$$

$$T_2 = \bar{g} + \frac{1}{3}e = \text{charge}(\bar{d}_g)$$

$$T_3 = \bar{b} + \frac{1}{3}e = \text{charge}(\bar{d}_b)$$

$$-T_1 = \overline{T_1} = r - \frac{1}{3}e = \text{charge}(d_r)$$

$$-T_2 = \overline{T_2} = g - \frac{1}{3}e = \text{charge}(d_g)$$

$$-T_3 = \overline{T_3} = b - \frac{1}{3}e = \text{charge}(d_b)$$

Placeholder: V ($=0$, *no* anti). Example: $TVT = T_1 + T_3 = \text{charge}(u_g)$

Tohu units are mutually orthogonal for *all* fermions: $(T_i \perp T_j)_{i \neq j}$

The 9, 3, and 1 Views of Internal Pion Forces

The Nine Standard Model Force Particles in Pions

Terry Bollinger
CC BY 4.0

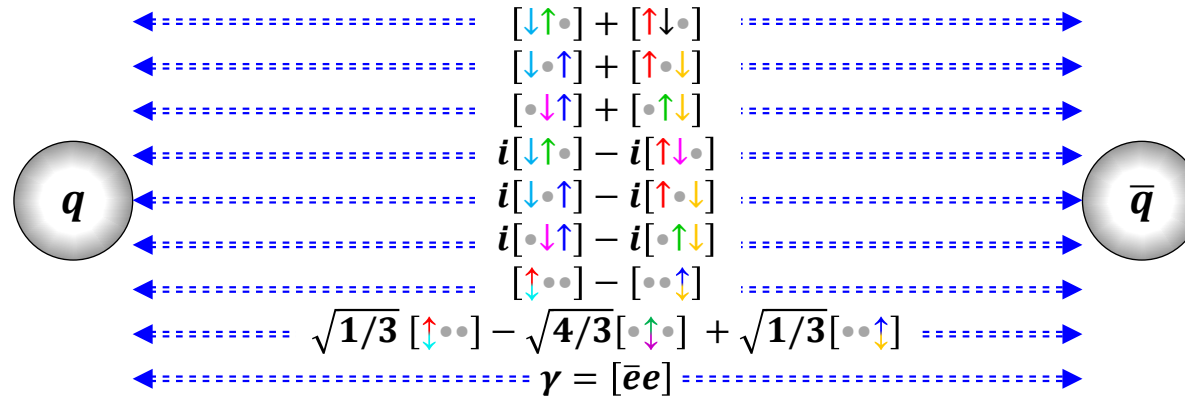

The Three Tohu Force Particles in Pions

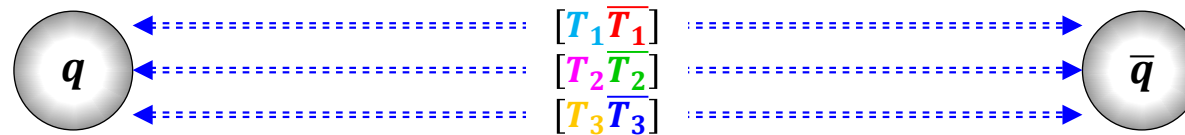

The Single Imposition Force Particle in Pions

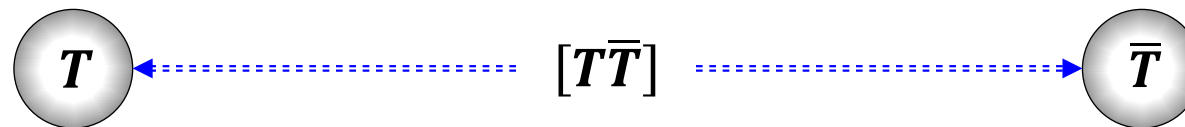

The Infinite Darkness of Hilbert Space

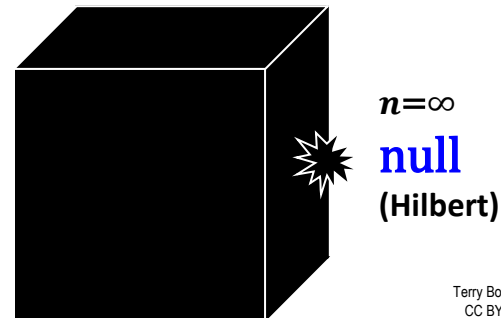
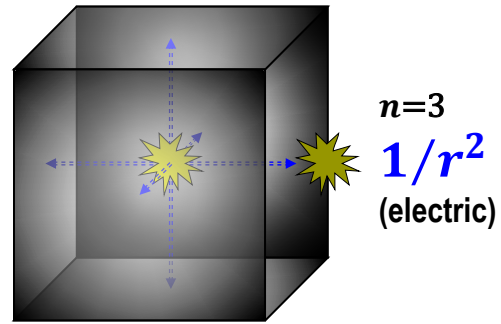
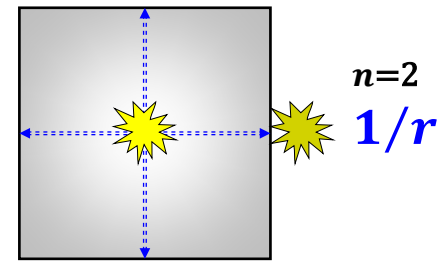
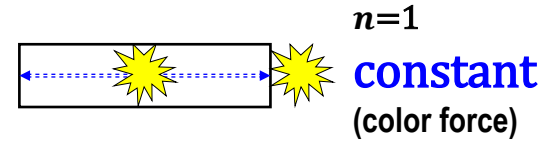

Terry Bollinger
CC BY 4.0

E+ and E- Fermion Groups

E^+ Fermion Group (Weak-Aware)

Terry Bollinger CC BY 4.0

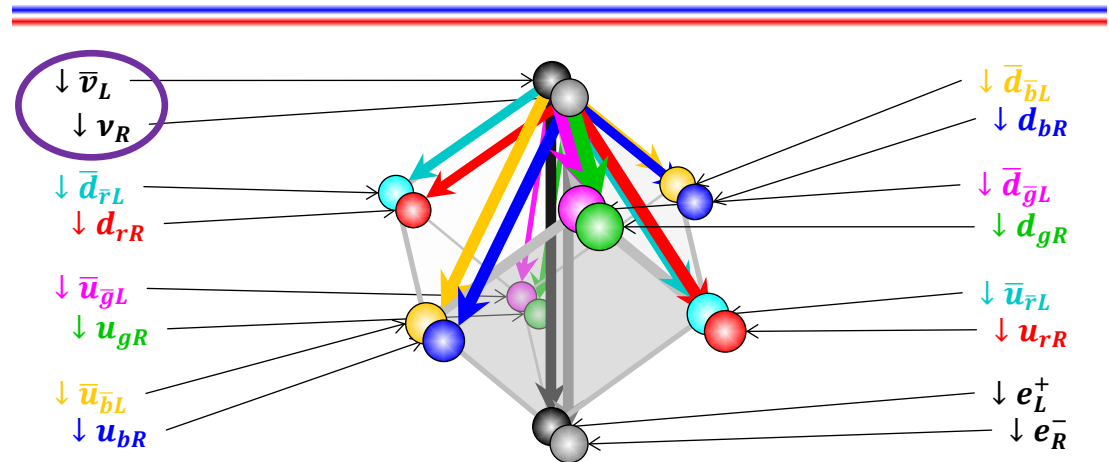
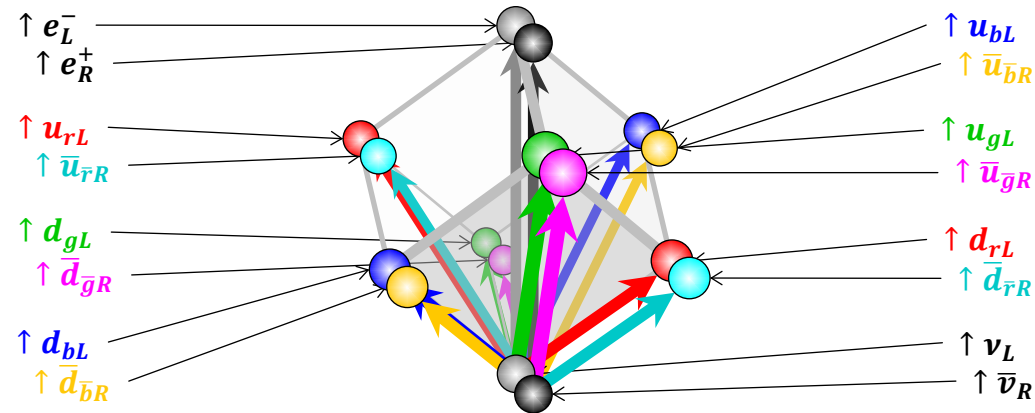

E^- Fermion Group (Weak-Blind)

Permitted (E+) and Forbidden (E-) Space Pairs

E^+ Space Pairs

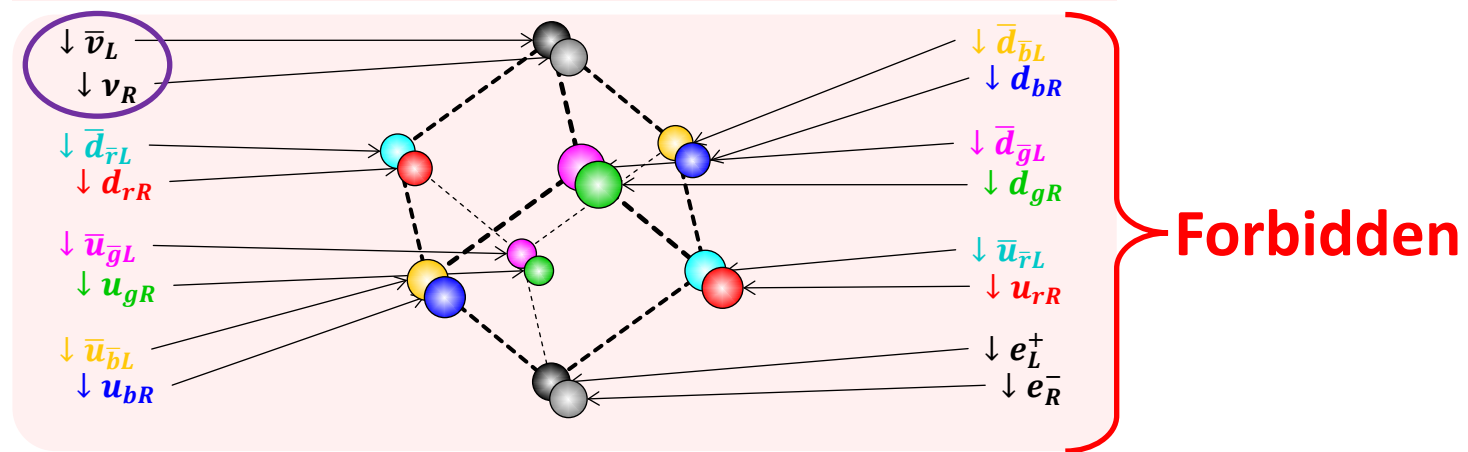
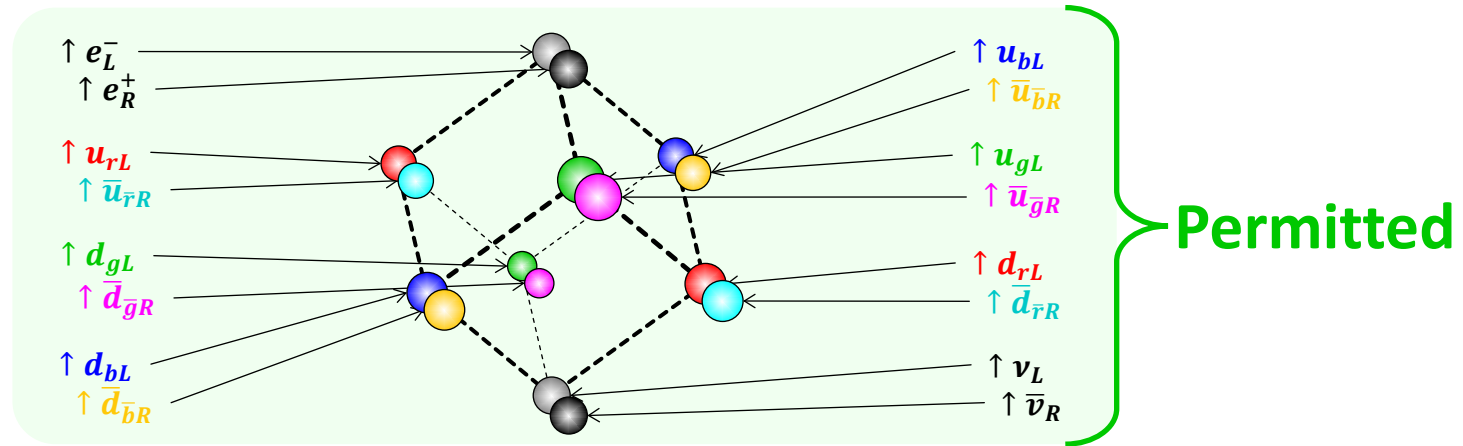

E^- Space Pairs

Space-Pair Creation and Annihilation

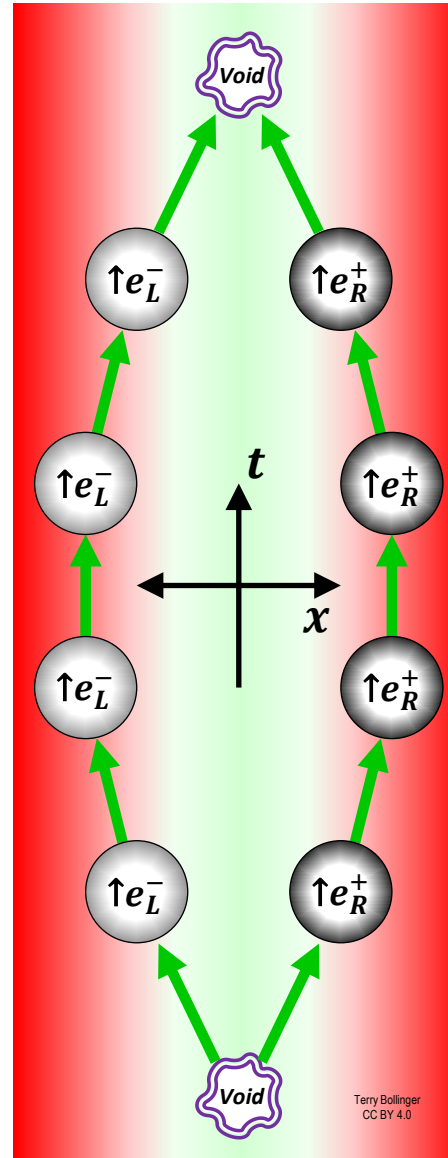

Time Pairs for Matter and Antimatter

Left-Handed Time Pairs

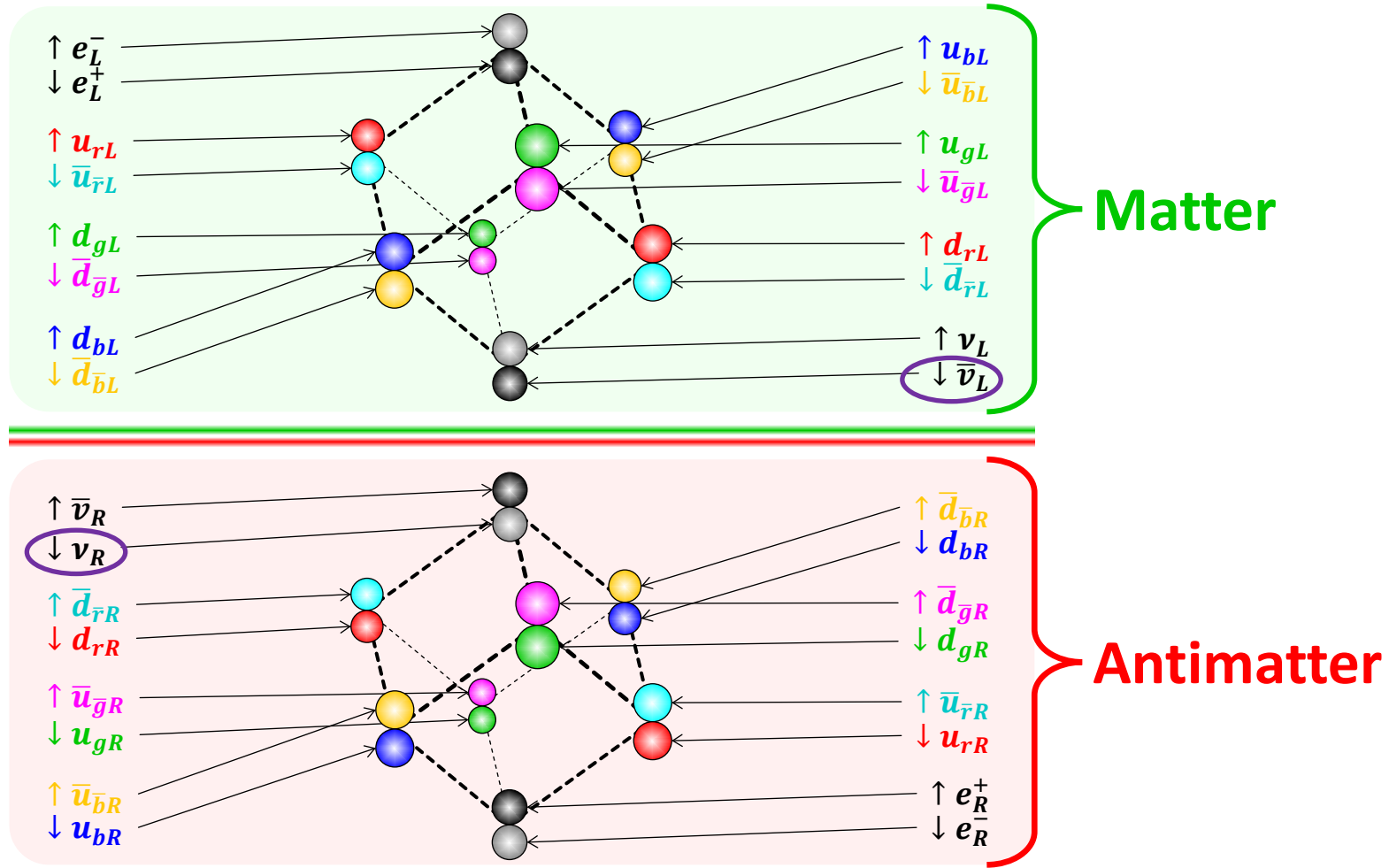

Right-Handed Time Pairs

Time-Pair Creation and Annihilation

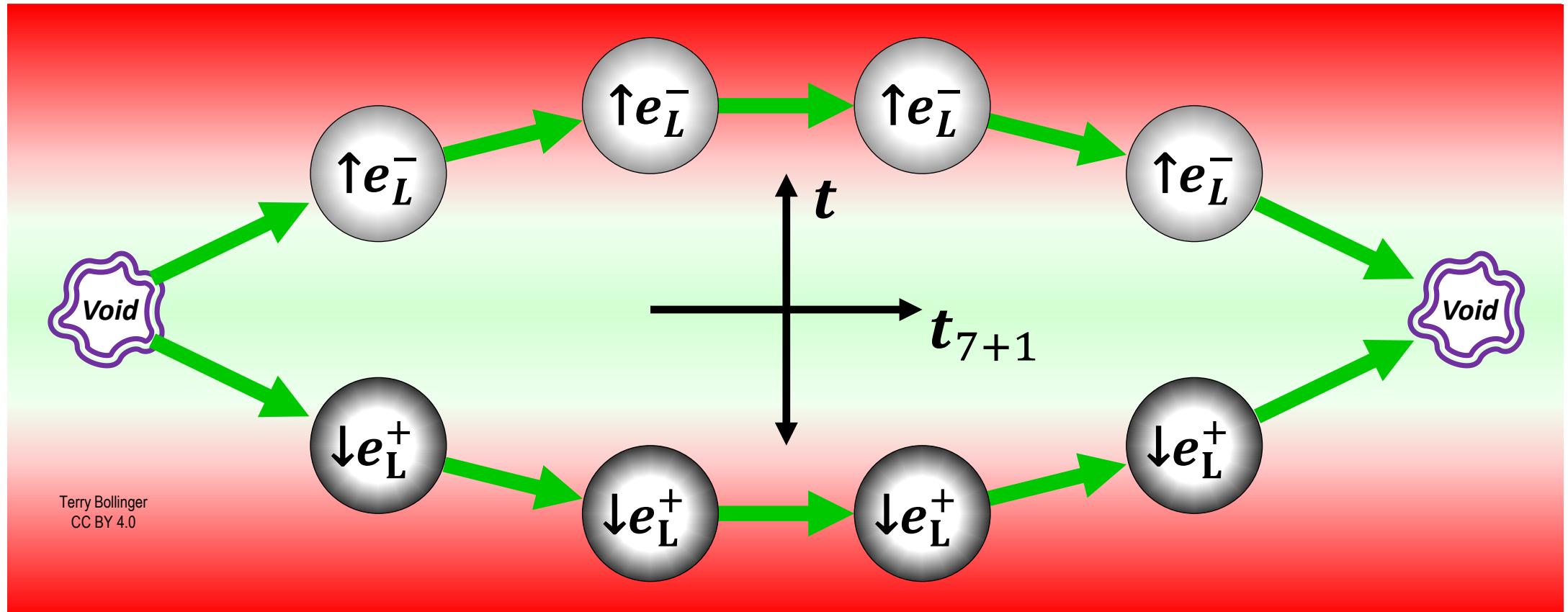

Time as Destabilized Time Pairs

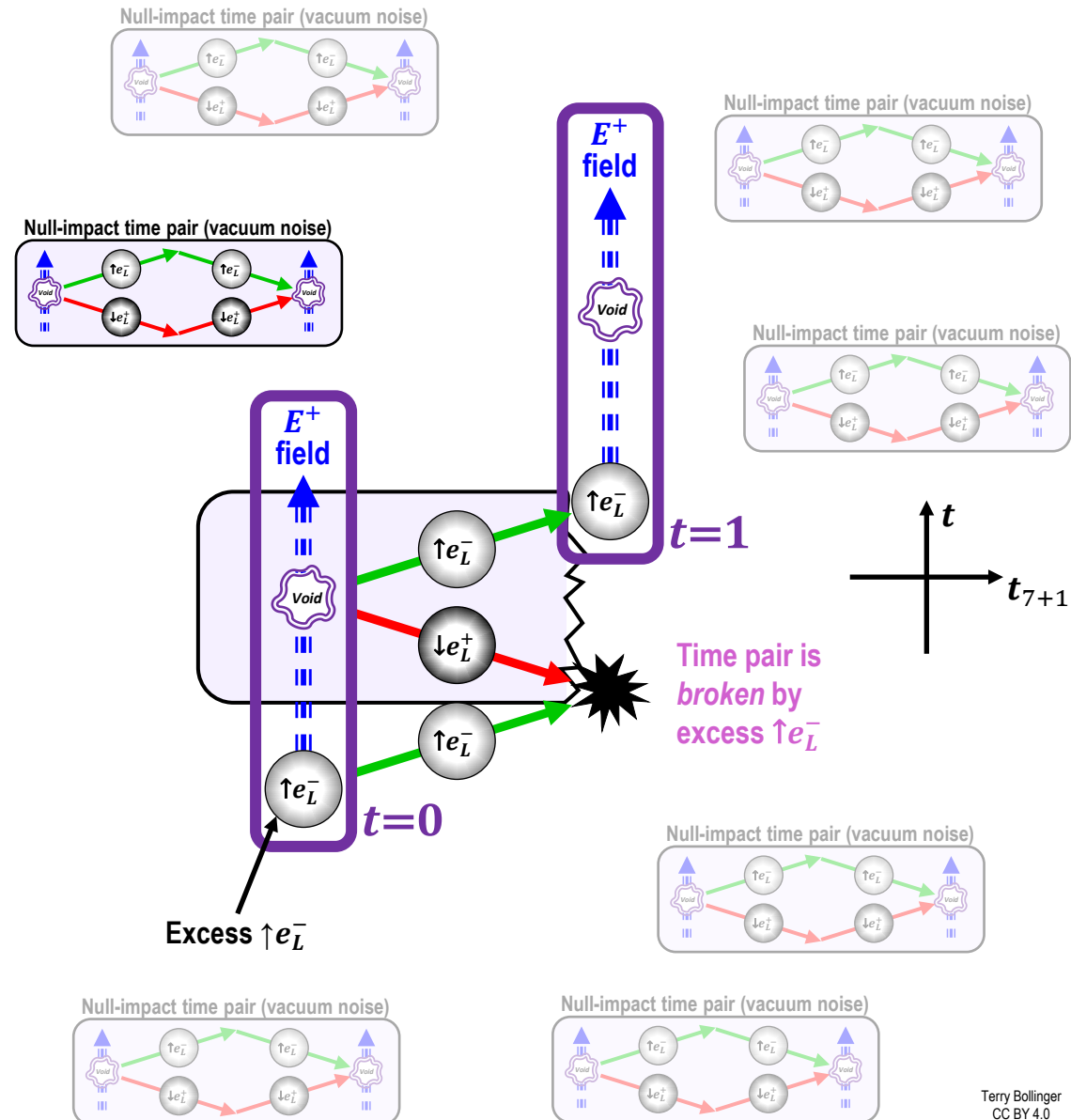

E+ Field and the Higgs Field

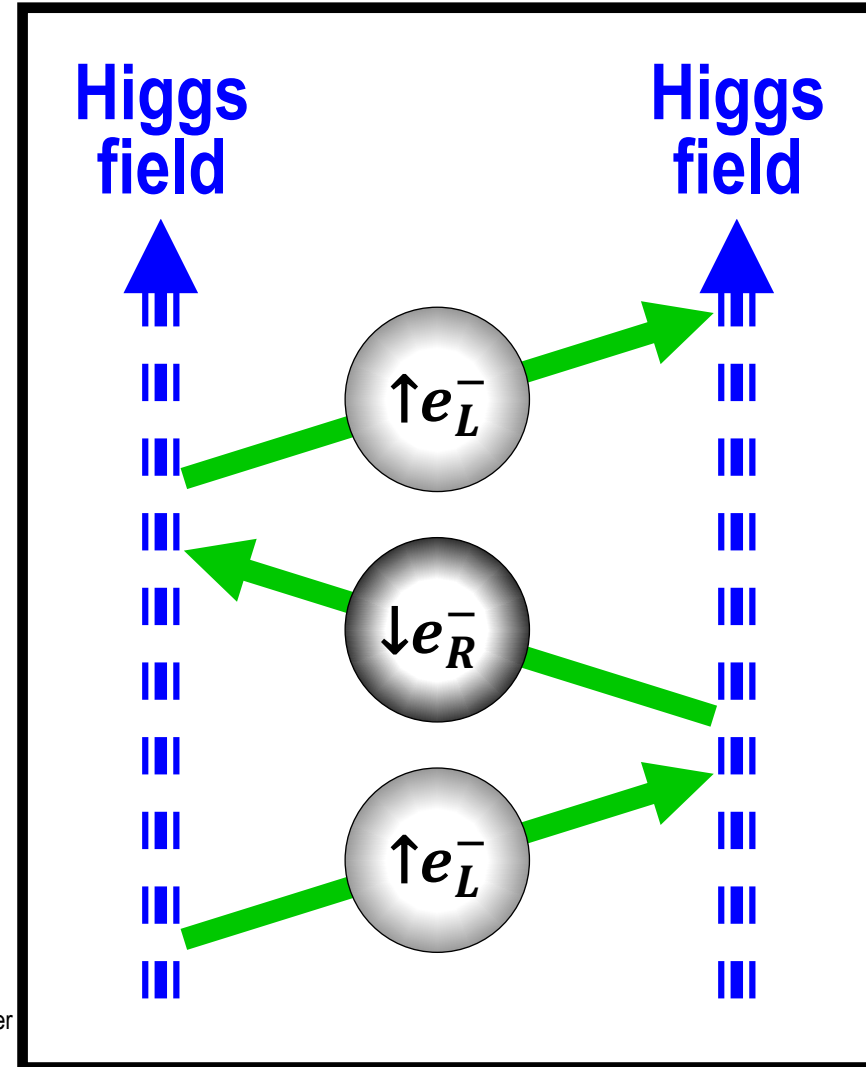
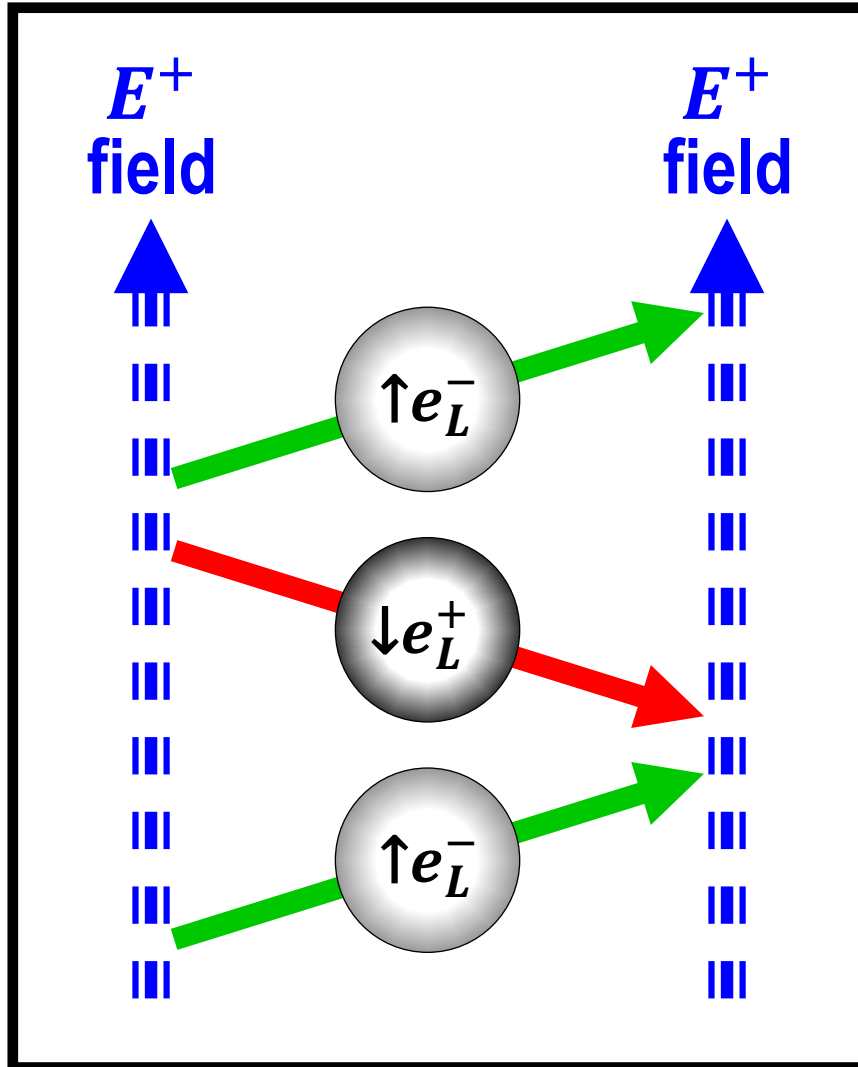

Terry Bollinger
CC BY 4.0

Holographic Information Waves

Schrödinger Image

- A dynamic *information hologram*
- Existence is defined by *external data*
- Hologram confines quantum numbers
- Image projected via momentum space

Holographic Information Wave

- Classical data expands at up to speed of light
- Composed mainly of phonons and photons
- This data encodes *all* knowledge on the wave
- Fourier transform provides holographic image

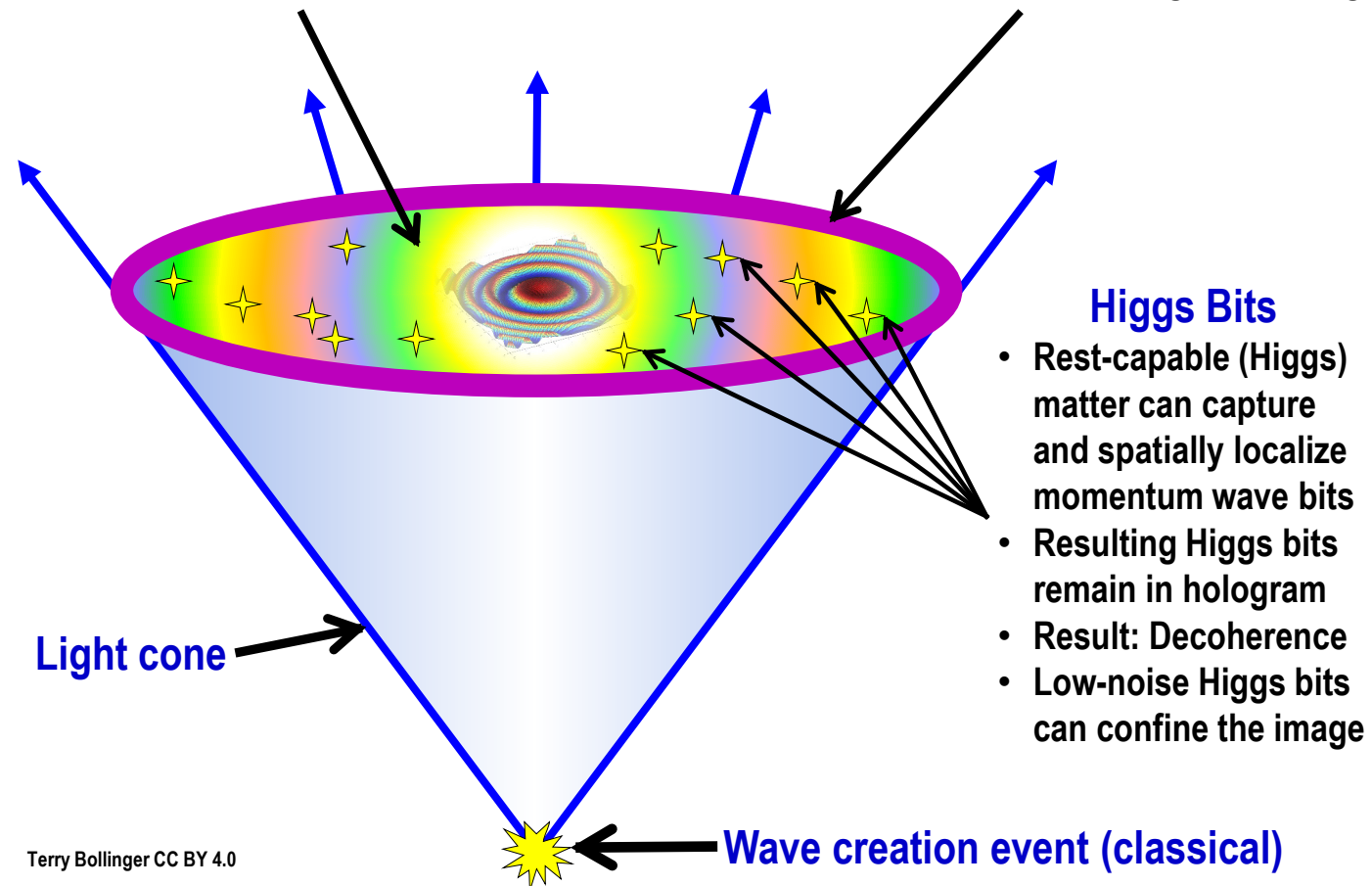

Holography and Bump Functions Don't Mix Well

- Bump functions (distributions) capture the idea of wave function *localization*
- Notably, Dirac delta functions are the mathematical limits of bump functions
- Bump functions splice functions to guarantee C^∞ smoothness, but at a cost
- Bump-splice boundaries require *infinite* (f/∞) Fourier spectrum (momentum)
- Not possible for energy-limited holography based on real particles in real space

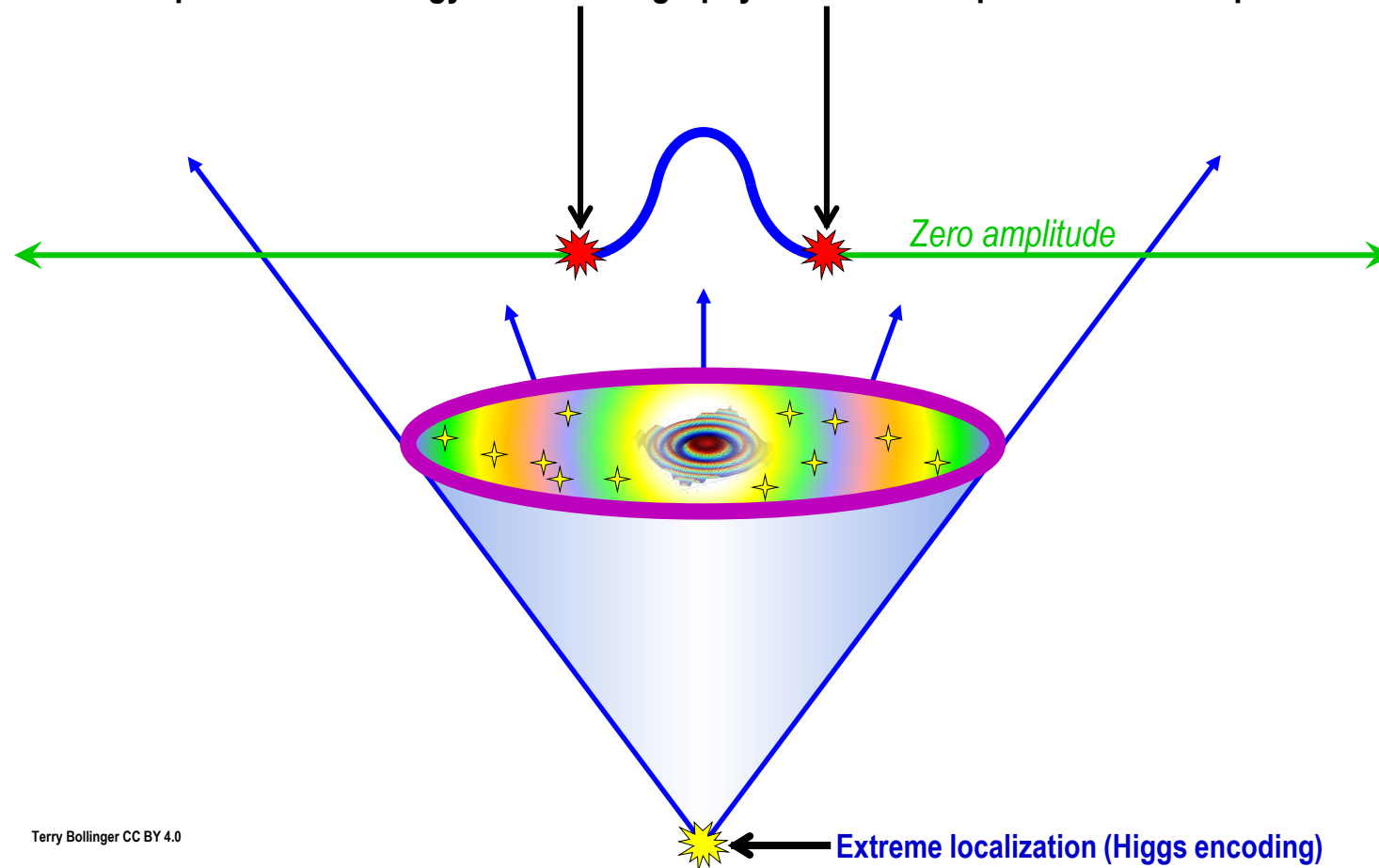

Light Cones Are Natural Quantum-Wave Boundaries

- An alternative: Shift the infinite-momentum bump boundaries out to the light cone
- The resulting boundary spectrum then matches with the SR momentum spectrum
- An interesting implication: Light cones are fundamentally *quantum* phenomena
- A second implication: Dirac delta functions are the *least* physical of distributions

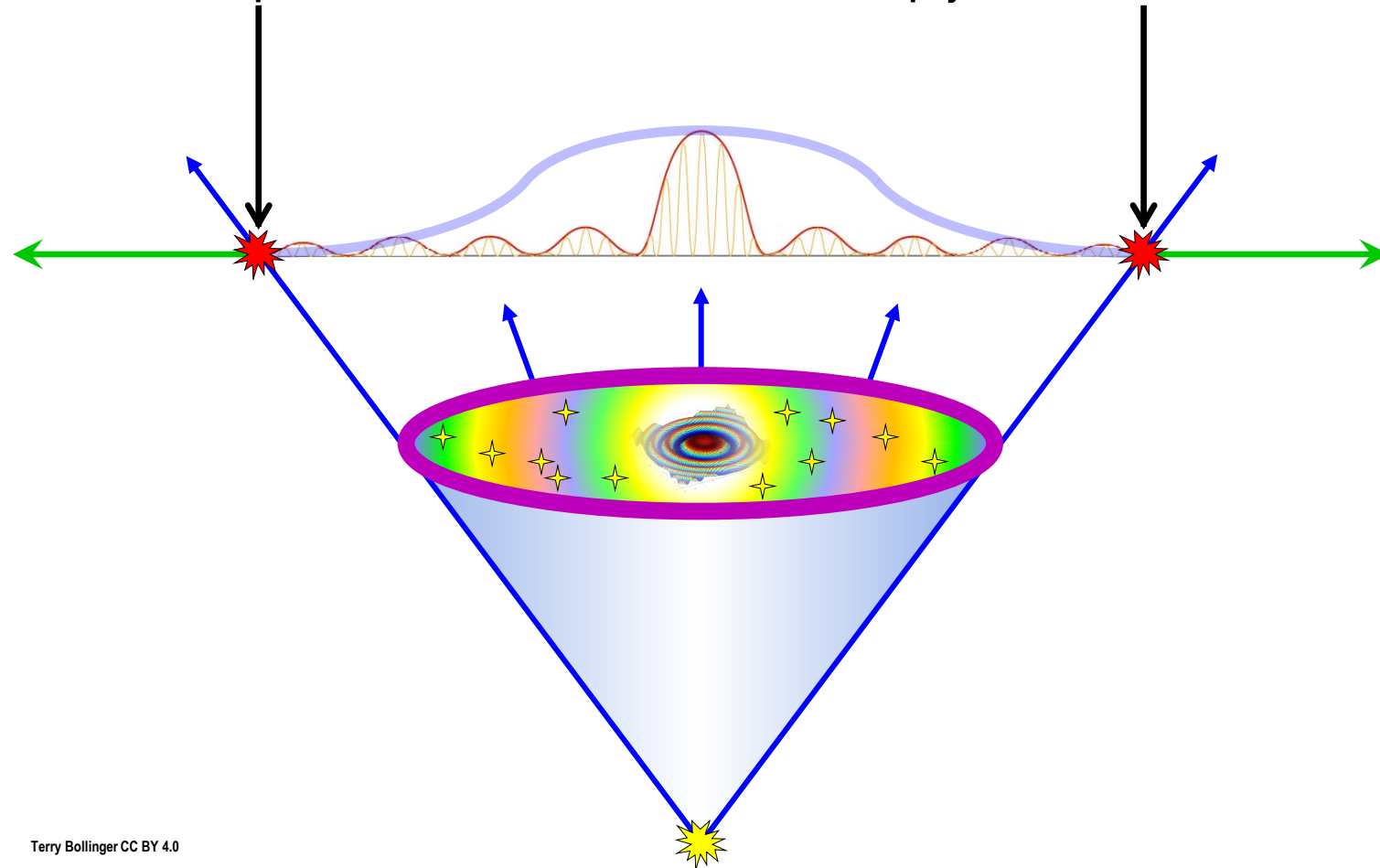



Ereboic Field Constraints on Exotic GR Solutions

Terry Bollinger CC BY 4.0

Permitted: Black Hole Cosmologies

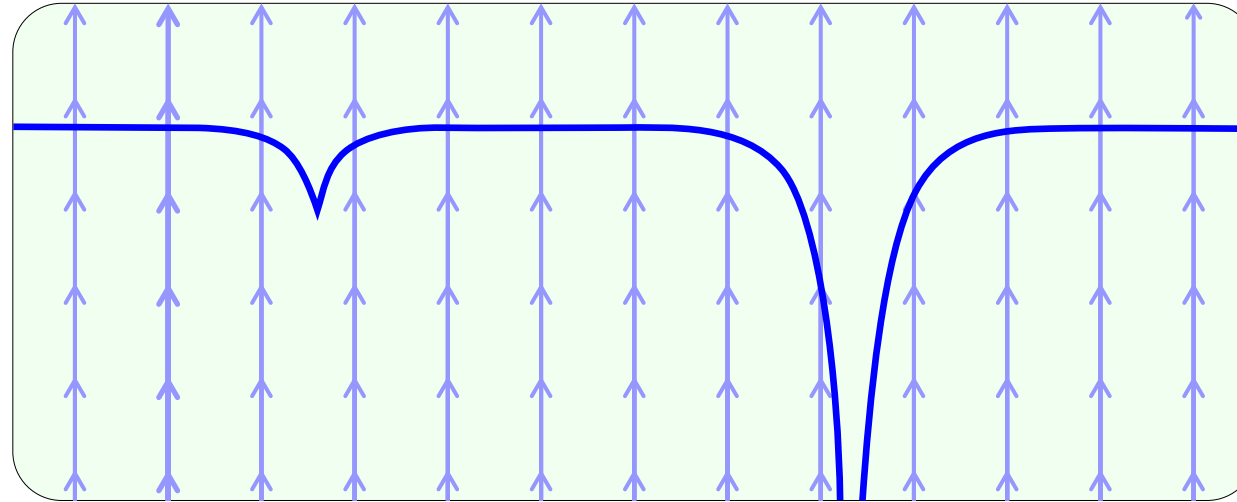

Forbidden: Wormhole Cosmologies

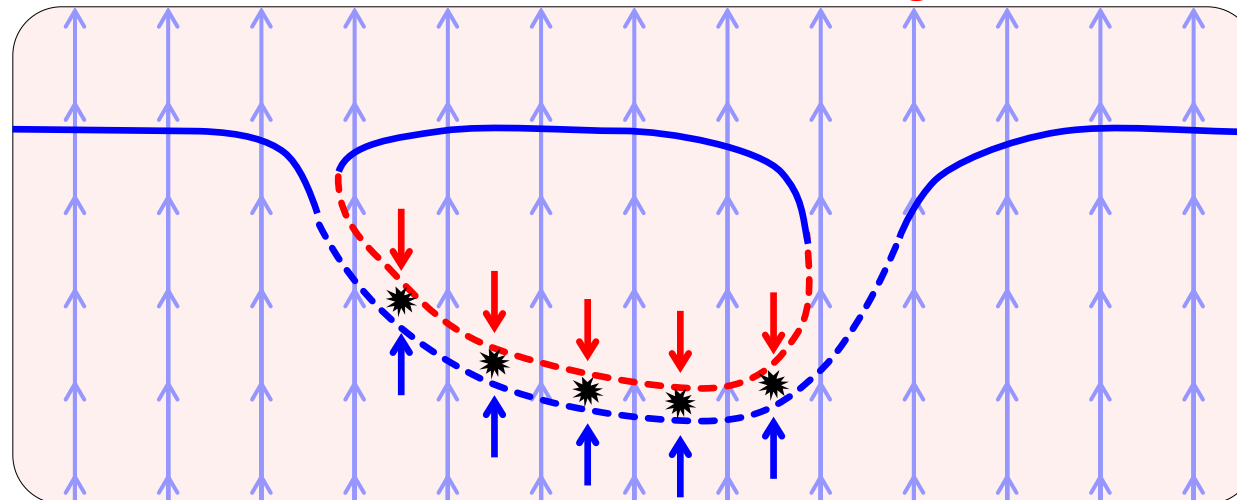



Reinterpreting Riemannian Manifolds

Terry Bollinger CC BY 4.0

Isotropically Parallel Manifolds

Issue (1): Infinite (C^∞) smoothness implies infinite precision, even at quantum scales

Issue (2): Simultaneous co-existing worlds sheets (here with ER bridges) are conceivable

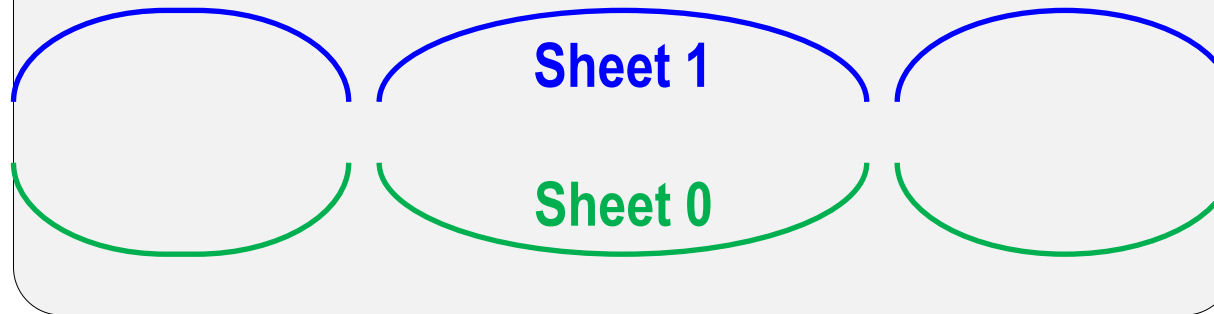

Time-Front Manifolds

(1) Resolution depends on available energy, and so becomes *blurred* at particle scales

(2) In time-front manifolds, adjacent parallel sheets imply *movement*, versus co-existence

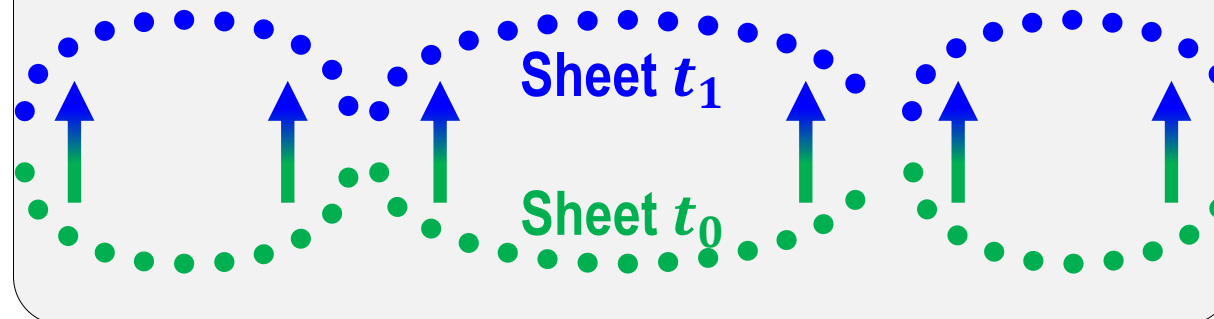

Einstein-Rosen Bridges

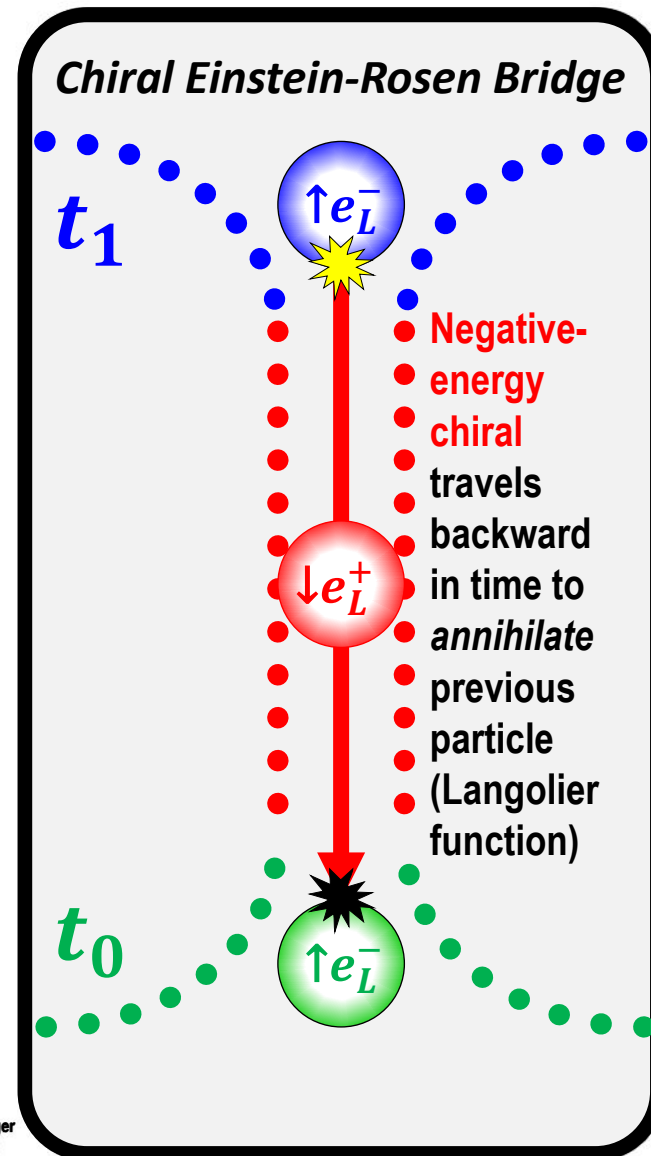
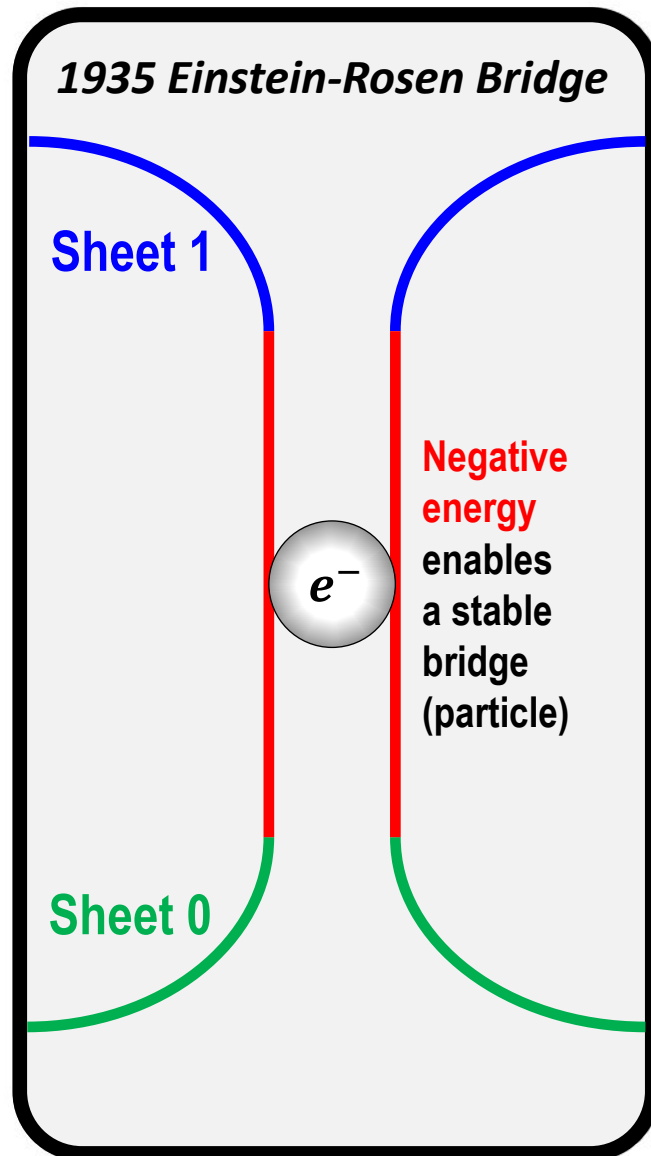

Terry Bollinger
CC BY 4.0